



Cucine a Legna

Il gusto della tradizione dallo stile moderno

Cadel rinnova completamente lo stile delle sue cucine a legna dando ad ognuna un tocco di modernità e migliorandone le prestazioni grazie alle nuove tecnologie presenti nel settore. Ecco che a quel senso di tradizione che naturalmente le cucine a legna ispirano, si uniscono praticità, innovazione, sicurezza ed ecosostenibilità dell'epoca moderna, per un connubio che mette tutti d'accordo. Elemento che unisce e accomuna tutti quanti è la vista della fiamma che riscalda anima e corpo e crea un'atmosfera speciale e unica. Le cucine Cadel grazie alla loro struttura in ghisa, garantiscono temperature gradevoli per molte ore del giorno. Tutte le cucine Cadel sono ecologiche e nei modelli insert la tecnologia utilizzata permette di riscaldare grandi spazi, garantendo sempre un'irradiazione e una distribuzione del calore omogeneo in tutta la stanza.

Tradition with a modern twist

Cadel completely renovated the style of its wood cookers by adding a modern touch and improving their performance thanks to the sector's new technologies. This way, the sense of tradition that wood cookers naturally have is combined with today's convenience, innovation, safety and environmental sustainability: a combination that meets everyone's needs.

What join and unit everybody is the fire sight warming soul and body and creating a special and unique atmosphere.

Thanks to their die-cast iron frame Cadel cookers guarantee pleasant temperatures for a long time during the day.

All Cadel cookers are eco-friendly and for insertable models the employed technology permits to heat large spaces always ensuring an homogeneous distribution of heat throughout the room.

Le gout de la tradition avec un style moderne

Cadel renouvelle complètement le style de ces cuisinières à bois avec une touche de modernité et en améliorant les performances grâce aux toutes dernières technologies du secteur.

Le résultat est l'union de la facilité d'utilisation, l'innovation, la sécurité et la durabilité environnementale d'un produit de nos jours avec un sens de tradition auquel ce type de cuisinière s'inspire.

L'élément commun, la vision des flammes, qui réchauffent l'âme et le corps et créent une atmosphère spéciale, unique. Grâce à leur structure en fonte de fer, les cuisinières Cadel garantissent des températures confortables durant de longues heures. Toutes les cuisinières Cadel sont écologiques et la technologie de tous les modèles encastrables permet de chauffer des espaces importants, garantissant ainsi un rayonnement et une distribution homogène de la chaleur dans toute la pièce.

Neigung zur Tradition mit modernem Stil

Cadel modernisiert den Stil der Holzherde und verbessert die Leistungen durch die neuen branchenspezifischen Technologien. Und so kommt es, dass Tradition, die man in den Holzherden wahrnimmt, mit Zweckmäßigkeit, Innovation, Sicherheit und Umweltverträglichkeit der modernen Zeiten vereint wird und somit alle möglichen Ansprüche und Wünsche befriedigt werden können.

Die Aussicht der Flamme, die Leib und die Seele erwärmt, schafft eine besondere und eigene Stimmung, die alle verbindet. Dank ihrer Struktur aus Gusseisen, Cadel-Herde versichern angenehme Temperaturen für lange Zeit. Alle Cadel-Herde sind ökologisch und die in allen einsetzbaren Modellen verwendete Technologie erlaubt, große Räume zu beheizen und gewährleistet eine gleichartige Ausstrahlung und Verteilung der Wärme in dem ganzen Raum.

SCHEMA DI FUNZIONAMENTO DELLE CUCINE A LEGNA CADEL

Scheme of how a Cadel wood burning cooker works
Schéma de fonctionnement des cuisinières à bois Cadel
Cadel Holzherde Betriebsplan



Ghisa speciale di grosso spessore
Special thick cast iron
Fonte spéciale de forte épaisseur
Spezielles dickes Gusseisen



Piano in vetro ceramico
Ceramic glass top
Plaque en vitrocéramique
Fläche aus Keramikglas

Sistema di preriscaldamento
aria comburente
Pre-heating system
with comburent air
Système de préchauffage
d'air comburant
Vorerhitzungssystem
Verbrennungsluft



Kit ventilazione automatica
e luce forno
Automatic ventilation kit
and oven light
Kit ventilation automatique et
lumière du four
Set automatische Belüftung
und Backofenbeleuchtung



Porta forno con doppio vetro
per facile pulizia
Oven door with double glazing to
easily clean the equipment
Porte du four avec double vitre
pour un nettoyage facile
Ofentür mit doppelter Glasscheibe
für eine problemlose Reinigung



Capiente forno in acciaio inox
con termostato
Large stainless steel oven
with thermostat
Grand four en acier inox
avec thermostat
Geräumiger Backofen aus
Inox-Stahl mit Thermostat



Cassettoni portalegna
Wood compartment
Gros tiroir pour contenir le bois
Holzkasten



Ampio cassetto cenere
Wide ash pan
Large tiroir pour les cendres
Geräumiger Aschenkasten



Griglia in ghisa ribaltabile
per rapida pulizia
Tip-over cast iron grid to
easily clean the equipment
Grille en fonte basculante
pour un nettoyage rapide
Kippbares Gitter aus
Gusseisen für rasche
Reinigung



Camera di combustione
in pietra refrattaria
Refractory stone
combustion chamber
Chambre de combustion
en pierre réfractaire
Verbrennungskammer
aus Schamotte



Piedini regolabili in altezza
(solo per modelli Kook 60-70)
Height-adjustable feet
(only for Kook 60-70 models)
Pieds réglables en hauteur (uniquement
pour les modèles Kook 60-70)
Höhenverstellbare Standfüße
(nur für Modelle Kook 60-70)

Cucine a Legna
da inserimento
JOLLY - 6,4 kW



Jolly



Interno in ghisa con aria 2^a combustione
Cast iron inner with 2nd combustion air
Intérieur fonte à apport d'air secondaire
Feuerraum aus Gusseisen mit Sekundärluftverbrennung



Cucinare
Cooking
Cuisiner
Kochen



Vista sul forno
View on the oven
Vue sur le four
Sicht des Backofens



Maniglia anti ustione
Burnproof handle
Poignée anti brûlure
Isolierter Griff



Ventilazione
Ventilation
Ventilation
Luftgebläse



Scarico fumi superiore e posteriore
Upper and back exhaust
Sortie fumée supérieure et postérieure
Abgasstutzen Hinten u. Oben

Cucine a Legna
da inserimento
JOLLY - 6,4 kW

Jolly



Il vero asso in cucina

Una cucina a legna ridotta, realizzata con il migliore acciaio per resistere alle temperature più elevate e per dare le migliori prestazioni in cucina. Il piano in acciaio permette di distribuire il calore in modo omogeneo, si scalda rapidamente ed è facile da pulire. I cibi possono essere cotti appoggiando le pentole sul piano oppure a diretto contatto con il fuoco grazie ai cerchi estraibili, senza dimenticare l'indispensabile forno in acciaio inox per cucinare secondo il metodo più classico e genuino.

Grazie alla camera in ghisa e al sistema di seconda combustione che sfrutta al massimo il potere energetico della legna, la cucina economica Jolly ha una maggiore resa termica e una minore emissione di sostanze inquinanti: un vero aiuto in cucina.

The real genius in the kitchen

A compact wood cooker made with the best steel to withstand the highest temperature and provide the best performance in the kitchen. The steel top evenly distributes the heat, warms up quickly and is easy to clean. Food can be cooked by placing the pots on the top or directly in contact with the fire thanks to the removable rings. Plus, there is the essential steel oven for authentic, classic cuisine. Thanks to the cast iron chamber and the second combustion system that makes the most of wood's energy capacity, the affordable Jolly cooker has a higher thermal output and releases fewer pollutants: a key support in the kitchen.

Le vrai axe dans la cuisine

Une cuisinière à bois réduite, réalisée avec le meilleur acier pour résister aux températures les plus élevées et pour offrir les meilleures prestations dans la cuisine. Le plan en acier permet de distribuer la chaleur de façon homogène, chauffe rapidement et facile à nettoyer. Les aliments peuvent être cuits en posant les casseroles sur la plaque ou bien en contact direct avec le feu grâce aux cercles amovibles, sans oublier le four en acier inox indispensable pour cuisiner selon la méthode plus classique et naturelle. Grâce à la chambre en fonte et au système de deuxième combustion qui exploite au maximum le pouvoir énergétique du bois, la cuisinière économique Jolly a un meilleur rendement thermique et une émission inférieure de substances polluantes : une vraie aide en cuisine.

Ein richtiges Ass in der Küche

Ein klein bemessener Holzherd aus erstklassigem Stahl für sehr hohe Temperaturen und beste Performance beim Kochen. Die Stahlplatte ermöglicht eine gleichmäßige Verteilung der Hitze, wird schnell heiß und ist leicht zu reinigen. Die Speisen können auf der Platte oder dank der abnehmbaren Ringe direkt am Feuer gekocht werden, ohne dass auf den unvermeidlichen Backofen aus Edelstahl vergessen wurde, der nach klassischer und natürlicher Methode bäckt. Durch die Gusseisenkammer und das System der sekundären Verbrennung, welche die Energie des Holzes restlos nutzt, hat der Herd Jolly eine höhere Wärmeabgabe und eine geringere Emission von Schadstoffen: eine wahre Hilfe in der Küche.

Jolly collection

JOLLY - 6,4 KW



6,4 kW



71,9 %



154 m³



Legna - Wood - Bois - Holz



1,9 kg/h



Ø 120 mm



119 kg



L 60 - P 60 - H 86 cm



4 cm



L 24,5 - P 38,5 - H 22 cm



L 16 - H 14,5 cm



0,43 m³



EN 12815:2001/A1:2004/AC:2007

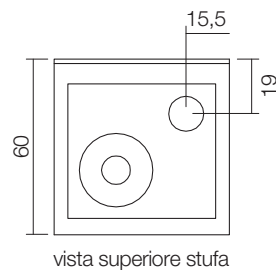

vista superiore stufa

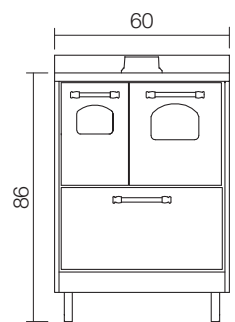

vista fronte stufa

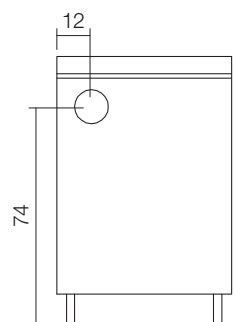

vista retro stufa



Metallo - Steel - Acier - Metall

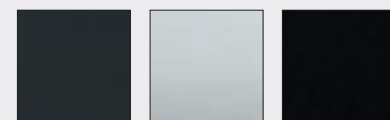

Antracite	Inox	Nero
Anthracite	Steel	Black
Anthracite	Inox	Noir
Anthrazit	Edelstahl	Schwarz

Cucine a Legna
da inserimento
KOOK 60 - 6,7 kW

Kook 60

Ideale per piccoli spazi
Ideal for confined spaces
Idéale pour les petits espaces
Ideal für enge Räume



Cucine a Legna
da inserimento
KOOK 60 - 6,7 kW



Kook 60



Interno in refrattario con aria 2^a combustione
Refractory stone inner with 2nd combustion air
Intérieur réfractaire à apport d'air secondaire
Feuerraum aus Schamotte mit Sekundärluftverbrennung



Cucinare
Cooking
Cuisiner
Kochen



Vista sul forno
View on the oven
Vue sur le four
Sicht des Backofens



Maniglia anti ustione
Burnproof handle
Poignée anti brûlure
Isolierter Griff



OPTIONAL
Kit ventilazione + luce / Ventilation + light kit
Ventilation + éclairage / Lüftung kit + Beleucht



Scarico fumi superiore centrale e posteriore centrale
Central top and back exhaust
Évacuation supérieure centrale et postérieure centrale
Abgasstutzen Oben und Hinten Zentral

Cucine a Legna
da inserimento
KOOK 60 - 6,7 kW

Kook 60



Modernità e forza dell'acciaio inox

Questa cucina a legna da incasso è ideale per gli spazi più ristretti.

Per coordinarsi con il resto dell'arredamento questa serie di cucine ad incasso Cadel è dotata di zoccolo regolabile in altezza. La struttura è in acciaio, la camera di combustione e piano cottura in ghisa: elementi pensati per ottenere la migliore resa per cucinare.

La ghisa è un ottimo conduttore termico, robusta e resistente al fuoco, mantiene il calore a lungo anche quando le fiamme sono spente, l'acciaio inox di cui è composto il forno di cottura si scalda rapidamente, è leggero e facile da pulire.

The modern feel and strength of stainless steel

This fitted wood cooker is ideal for confined spaces. To blend in with the rest of the interior, this series of Cadel fitted cookers has a height-adjustable skirting board. It has a steel frame, a combustion chamber and a cast iron top: elements designed for top performance when cooking.

Cast iron is an excellent thermal conductor, sturdy and resistant to fire. It retains heat for an extended period of time even after the hobs have been turned off. Stainless steel, which the oven is made of, heats up quickly, is light and easy to clean.

Modernité et solidité de l'acier inox

Cette cuisinière à bois encastrable est la plus petite de la famille ce qui la rend idéale pour les espaces étroits. Pour s'harmoniser avec les meubles qui l'entourent cette ligne de cuisinières encastrables Cadel est pourvue de socle réglable en hauteur pour que le profil se nivèle parfaitement aux autres meubles.

La structure est en acier, tandis que la chambre de combustion et la plaque de cuisson sont en fonte, l'élément idéal pour une meilleure performance de cuisson. La fonte reste un des meilleurs conducteurs thermiques, solide et résistante aux hautes températures, elle a comme avantage celui de maintenir la chaleur pour longtemps après que les flammes se sont éteintes, l'acier inox, utilisé pour le four, de son côté est aussi très résistant à la chaleur, tout en étant léger et pratique pour le nettoyage.

Modernheit und Stärke des Inox-Stahls

Dieser Einbau-Holzherd ist ideal für enge Räume. Die Einbauherde Cadel dieser Serie sind für die Koordination mit der bestehenden Einrichtung mit einem höhenverstellbaren Sockel ausgestattet. Die Struktur ist aus Stahl, die Verbrennungskammer und die Kochfläche aus Gusseisen: Diese Elemente wurden für einen besseren Wirkungsgrad beim Kochen ausgedacht.

Das Gusseisen ist ein optimaler Wärmeleiter, robust und feuerfest, bleibt auch nach Auslöschen der Flammen lange heiß, der Edelstahl aus dem der Backofen besteht erhitzt rasch, ist leicht und einfach zu reinigen.

Kook 60 collection

KOOK 60 - 6,7 KW

-  6,7 kW
-  76,3 %
-  161 m³
-  Legna - Wood - Bois - Holz
-  2,00 kg/h
-  Ø 120 mm
-  126 kg
-  L 60 - P 60 - H 85/90 cm
-  4 cm
-  L 37 - P 34 - H 17 cm
-  L 21,6 - H 13,5 cm
-  0,47 m³

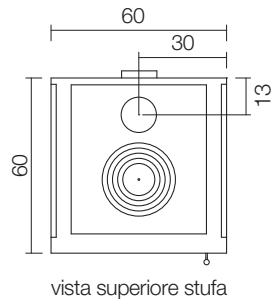

vista superiore stufa

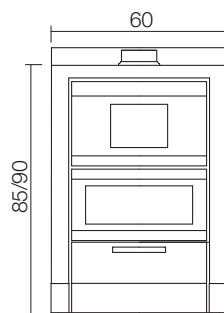

vista fronte stufa

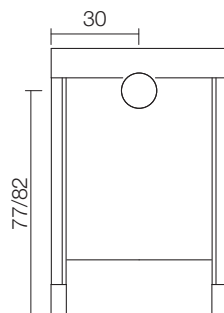

vista retro stufa



Metallo - Steel - Acier - Metall



Antracite	Bianco	Inox	Nero
Anthracite	White	Steel	Black
Anthracite	Blanc	Inox	Noir
Anthrazit	Weiss	Edelstahl	Schwarz



EN 12815:2001/A1:2004/AC:2007



NORMATIVE EUROPEE: BImSchV 2015 Regensburg München Stuttgart Aachen

Cucine a Legna
da inserimento
KOOK 70 - 6,7 kW

Cucinare secondo tradizione
Cooking according to tradition
Cuisiner selon la tradition
Kochen nach Tradition



Kook 70



Cucine a Legna
da inserimento
KOOK 70 - 6,7 kW



Kook 70



Interno in refrattario con aria 2^a combustione
Refractory stone inner with 2nd combustion air
Intérieur réfractaire à apport d'air secondaire
Feuerraum aus Schamotte mit Sekundärluftverbrennung



Cucinare
Cooking
Cuisiner
Kochen



Vista sul forno
View on the oven
Vue sur le four
Sicht des Backofens



Maniglia anti ustione
Burnproof handle
Poignée anti brûlure
Isolierter Griff



OPTIONAL
Kit ventilazione + luce / Ventilation + light kit
Ventilation + éclairage / Lüftung kit + Beleucht



Scarico fumi superiore centrale e posteriore centrale
Central top and back exhaust
Évacuation supérieure centrale et postérieure centrale
Abgasstutzen Oben und Hinten Zentral

Cucine a Legna
da inserimento
KOOK 70 - 6,7 kW

Kook 70



Tradizione e innovazione si incontrano...

Grazie alle nuove tecnologie apportate anche le prestazioni delle cucine a legna da inserimento Kook 70 sono nettamente migliorate, permettendo di avere una resa maggiore dal punto di vista termico e minori emissioni inquinanti. Un metodo di cucina legato ai tempi passati ma ecologico e moderno. Ma non tutto ciò che appartiene al passato deve essere aggiornato, anche in questo modello Cadel ha voluto lasciare nel piano cottura i cerchi estraibili di diverse grandezze che consentono di porre le pentole direttamente a contatto con il fuoco e agevolare la cottura dei cibi.

Tradition meets innovation...

Thanks to new technologies, the performance of the Kook 70 fitted wood cookers has considerably improved, allowing for a greater thermal output and lower polluting emissions. A cooking method from the past and yet eco-friendly and modern. Not everything belonging to the past needs to be updated. Cadel decided to leave the removable rings in various sizes on the hob. The rings are used to place the pots directly in contact with the fire and make food easier to cook.

La rencontre entre tradition et innovation

Grace aux nouvelles technologies introduites les performances des cuisinières à bois Cadel se sont nettement améliorées, permettant ainsi d'avoir un meilleur rendement du point de vue énergétique et, par conséquent, des émissions inférieures. Une méthode de cuisson liée au passé qui devient maintenant écologique et pratique avec les avantages d'un produit de conception moderne. Car moderniser un produit signifie aussi garder ce qu'il y a de bon dans la tradition et nous a permis de former notre savoir-faire ; pour cela Cadel n'abandonne pas la plaque de cuisson en fonte avec les traditionnels cercles

Tradition und Innovation begegnen sich ...

Die neuen Technologien haben auch die Performance der Einbau-Holzherde Kook 70 merkbar verbessert: höhere Wärmeabgabe und geringere Schadstoffemissionen. Ein Herd, der an vergangene Zeiten gebunden aber trotzdem ökologisch und modern ist. Aber nicht alles was der Vergangenheit angehört muss erneuert werden, auch in diesem Modell hat Cadel die abnehmbaren Ringe verschiedener Größen gelassen, die es ermöglichen, die Speisen direkt am Feuer zu kochen bzw. zu garen.

Kook 70 collection

KOOK 70 - 6,7 KW

-  6,7 kW
-  76,3 %
-  161 m³
-  Legna - Wood - Bois - Holz
-  2,00 kg/h
-  Ø 120 mm
-  128 kg
-  L 70 - P 60 - H 85/90 cm
-  4 cm
-  L 37 - P 34 - H 17 cm
-  L 21,6 - H 13,5 cm
-  0,59 m³

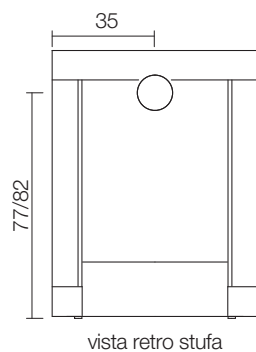
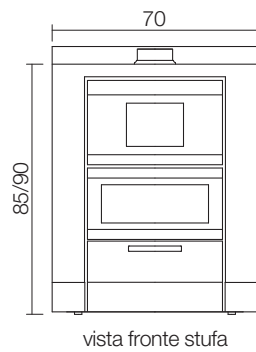
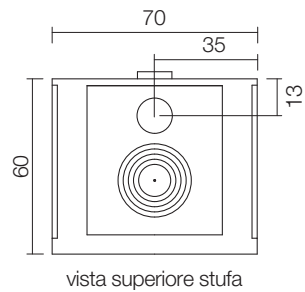

Metallo - Steel - Acier - Metall



Antracite	Bianco	Inox	Nero
Anthracite	White	Steel	Black
Anthracite	Blanc	Inox	Noir
Anthrazit	Weiss	Edelstahl	Schwarz



EN 12815:2001/A1:2004/AC:2007

NORMATIVE EUROPEE: BlmSchV 2015 Regensburg München Stuttgart Aachen

Cucine a Legna
da inserimento
KOOK 80 - 7,5 kW

Kook 80

*Forno capiente e funzionale
Spacious and functional oven
Grand four fonctionnel
Geräumiger und
funktionstüchtiger Backofen*



ROBEK

Cucine a Legna
da inserimento
KOOK 80 - 7,5 kW



Elegante piano in vetroceramica
Elegant glass ceramic top
Élégante plaque en vitrocéramique
Elegante Fläche aus Glaskeramik



Kook 80



Interno in refrattario con aria 2^a combustione
Refractory stone inner with 2nd combustion air
Intérieur réfractaire à apport d'air secondaire
Feuerraum aus Schamotte mit Sekundärluftverbrennung



Cucinare
Cooking
Cuisiner
Kochen



Vista sul forno
View on the oven
Vue sur le four
Sicht des Backofens



Maniglia anti ustione
Burnproof handle
Poignée anti brûlure
Isolierter Griff



OPTIONAL
Kit ventilazione + luce / Ventilation + light kit
Ventilation + éclairage / Lüftung kit + Beleucht



Scarico fumi superiore destro e posteriore destro
Upper right and back right exhaust
Évacuation supérieure et postérieure droite
Abgasstutzen Oben und Hinten Rechts

Cucine a Legna
da inserimento
KOOK 80 - 7,5 kW

Kook 80



Più spazio alla cucina

In questa cucina a legna da inserimento ciò che colpisce è lo spazio dedicato al forno, l'ampio vetro permette di vedere i cibi in cottura e l'ampio focolare, così che tutto sia subito sotto controllo.

Il grande forno è in acciaio inox per una cottura omogenea e una facile pulizia mentre il piano cottura che di serie è in ghisa è disponibile anche in vitroceramica. Il comodo cassettone scorrevole permette di tenere la legna a portata di mano, il tutto pensato per dare grande funzionalità ed ergonomicità agli amanti dell'arte del cucinare.

More space in the kitchen

The striking element of this fitted wood cooker is the space devoted to the oven, the wide glass through which you can see the food cooking and the wide firebox, so you can have everything under control. The big, stainless steel oven ensures food is cooked evenly and the appliance is easy to clean, while the hob made of cast iron as standard is also available in a glass ceramic version. With the large, practical sliding drawer, everything is within easy reach and everything is designed to provide great functionality and economics to those who love to cook.

Plus de place à la cuisine

Ce qui nous touche dans cette cuisinière encastrable est la place dédiée au four. Deux ouvertures en verre parallèles permettent de voir d'un côté la cuisson des plats et de l'autre le grand foyer en réfractaire. De cette façon tout est sous contrôle. Le grand four est réalisé en acier inox pour une cuisson plus homogène et un nettoyage plus facile, tandis que la plaque de cuisson, qui d'origine est en fonte peut être aussi commandé en vitrocéramique noir. Sur le bas, un grand tiroir rétractable peut servir à conserver le bois ou des outils de cuisine toujours à portée de main, des solutions ergonomiques et fonctionnelles pour que cuisiner reste un plaisir.

Ein größerer Raum im Herd

Was bei diesem Einbau-Holzherd sofort auffällt ist das geräumige Backrohr; die große Glasscheibe ermöglicht, die Speisen beim Backen und den großen Feuerraum zu beobachten, so dass alles unter Kontrolle ist. Das geräumige Backrohr ist aus Inox-Stahl für ein gleichmäßiges Backen und leichtes Reinigen, die Kochfläche ist serienmäßig aus Gusseisen gefertigt, ist aber auch aus Keramikglas erhältlich. Die bequeme Lade dient als Stauraum für das Holz, damit es stets griffbereit ist. Zweckmäßigkeit und Ergonomie: das Richtige für die Liebhaber der Kochkunst.

Kook 80 *collection*

KOOK 80 - 7,5 KW

-  7,5 kW
-  82,5 %
-  180 m³
-  Legna - Wood - Bois - Holz
-  2,2 kg/h
-  Ø 140 mm
-  136 kg
-  L 80 - P 60 - H 85,5 cm
-  4 cm
-  L 33 - P 42 - H 29 cm
-  L 17,2 - H 16,7 cm
-  0,68 m³

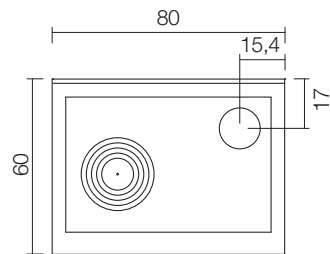

vista superiore stufa



vista fronte stufa

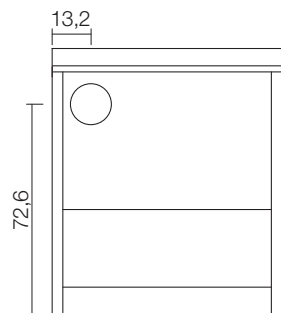

vista retro stufa



Metallo - Steel - Acier - Metall



- | | | | |
|------------|--------|-----------|---------|
| Antracite | Bianco | Inox | Nero |
| Anthracite | White | Steel | Black |
| Anthracite | Blanc | Inox | Noir |
| Anthrazit | Weiss | Edelstahl | Schwarz |



EN 12815:2001/A1:2004/AC:2007

NORMATIVE EUROPEE: Art. 15AB-VG2015 BImSchV2015 Regensburg München Stuttgart Aachen

Cucine a Legna
da inserimento
KOOK 90 - 7,5 kW

Forno capiente e funzionale
Large and functional oven
Four plus grand et fonctionnel
Geräumiger und funktioneller Backofen



Kook 90



Cucine a Legna
da inserimento
KOOK 90 - 7,5 kW



Kook 90



Interno in refrattario con aria 2^a combustione
Refractory stone inner with 2nd combustion air
Intérieur réfractaire à apport d'air secondaire
Feuerraum aus Schamotte mit Sekundärluftverbrennung



Cucinare
Cooking
Cuisiner
Kochen



Vista sul forno
View on the oven
Vue sur le four
Sicht des Backofens



Maniglia anti ustione
Burnproof handle
Poignée anti brûlure
Isolierter Griff



OPTIONAL
Kit ventilazione + luce / Ventilation + light kit
Ventilation + éclairage / Lüftung kit + Beleucht



Scarico fumi superiore destro e posteriore destro
Upper right and back right exhaust
Évacuation supérieure et postérieure droite
Abgasstutzen Oben und Hinten Rechts

Cucine a Legna
da inserimento
KOOK 90 - 7,5 kW

Kook 90



Maxi taglia per maxi prestazioni

Kook 90 è la cucina a legna da inserimento più grande della collezione Cadell, studiata per ampi spazi e per rendersi protagonista assoluta dell'ambiente, disponibile in quattro diverse colorazioni in metallo.

Tutte le dimensioni rispettano gli standard di costruzione delle cucine per essere inserite alla perfezione anche in spazi già esistenti.

Kook 90 combina le grandi dimensioni a soluzioni tecniche innovative, come il sistema di ventilazione che distribuisce l'aria calda in modo omogeneo in tutto l'ambiente e grandi prestazioni nella cottura del cibo grazie ai nuovi piani cottura in vetroceramica.

A large size for great performance

Kook 90 is the biggest fitted wood cooker in the Cadell collection. It is designed for large spaces and becomes the absolute centre piece of the room.

All dimensions comply with the construction standards of cookers built to be perfectly fitted into existing areas.

Kook 90 combines its large size with innovative technical solutions, such as the ventilation system that evenly distributes warm air across the whole room and great performance when cooking food thanks to the new glass ceramic hobs.

Grande taille pour des grandes performances

Kook 90 est la plus grande cuisinière à bois encastrable de la gamme Cadell, pensée pour des espaces plus importants, elle sera protagoniste dans votre cuisine, avec ces quatre coloris disponibles.

Toutes les dimensions respectent les standards des constructeurs de cuisinières pour s'adapter à la perfection aux cuisines neuves et existantes. Kook 90 réuni des grandes dimensions et des solutions techniquement innovantes, comme le système de ventilation qui distribue l'air chaud de façon homogène et pour longtemps dans toute l'ambiance, à des grandes performances de cuisson grâce aux nouveaux plans de cuisson en vitrocéramique ou en fonte.

Maxi-Größe für Maxi-Leistungen

Kook 90 ist der größte Einbau-Holzherd der Kollektion Cadell, gedacht für große Räume, in denen er eine wichtige Rolle spielt; aus Metall, in vier verschiedenen Farben erhältlich.

Sämtliche Abmessungen entsprechen den Bau-Standards der Herde, um auch in einen bereits bestehenden Platz perfekt eingefügt werden zu können.

Kook 90 kombiniert die großen Abmessungen mit innovativen technischen Lösungen, so das Belüftungssystem, das die warme Luft im ganzen Raum verteilt und große Leistungen beim Garen der Speisen dank der neuen Kochplatten aus Keramikglas.

Kook 90 *collection*

KOOK 90 - 7,5 KW

-  7,5 kW
-  82,5 %
-  180 m³
-  Legna - Wood - Bois - Holz
-  2,2 kg/h
-  Ø 140 mm
-  138 kg
-  L 90 - P 60 - H 85,5 cm
-  4 cm
-  L 33 - P 42 - H 29 cm
-  L 17,2 - H 16,7 cm
-  0,68 m³

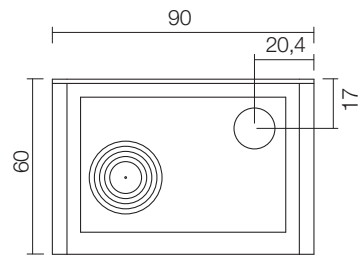

vista superiore stufa

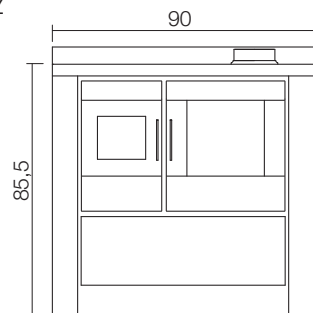

vista fronte stufa

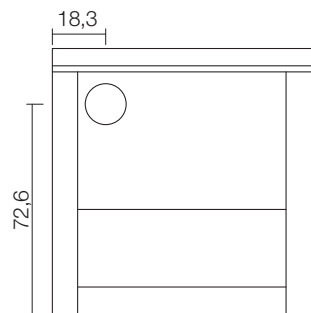

vista retro stufa



Metallo - Steel - Acier - Metall



Antracite	Bianco	Inox	Nero
Anthracite	White	Steel	Black
Anthracite	Blanc	Inox	Noir
Anthrazit	Weiss	Edelstahl	Schwarz



EN 12815:2001/A1:2004/AC:2007

NORMATIVE EUROPEE: Art. 15 AB-VG 2015 BImSchV 2015 Regensburg München Stuttgart Aachen

Cucine a Legna
libera installazione
SMART - 6 kW



Smart



La cucina Smart
The smart wood burning cooker
La cuisinière smart
Die Smart-Küche



Cucine a Legna
libera installazione
SMART - 6 kW



Smart



Interno in ghisa con aria 2^a combustione
Cast iron inner with 2nd combustion air
Intérieur fonte à apport d'air secondaire
Feuerraum aus Gusseisen mit Sekundärluftverbrennung



Cucinare
Cooking
Cuisiner
Kochen



Vista sul forno
View on the oven
Vue sur le four
Sicht des Backofens



Maniglia anti ustione
Burnproof handle
Poignée anti brûlure
Isolierter Griff



Scarico fumi
superiore destro
Top right exhaust outlet
Évacuation fumées
supérieure droite
Abgasstutzen Oben Rechts



Scarico fumi
superiore centrale
Central top exhaust outlet
Évacuation sup. central
Abgasstutzen Oben Zentral



Scarico fumi
posteriore destro
Right back exhaust outlet
Évacuation fumées
postérieure droite
Abgasstutzen Hinten Rechts

Cucine a Legna
libera installazione
SMART - 6 kW

Smart



L'essenziale in cucina

Riscaldare e cucinare con pochi semplici gesti. Con Smart, la cucina a legna freestanding di Cadel, è possibile farlo in modo intelligente, perché creata con essenzialità funzionale, la complice perfetta del benessere di casa. Pratica ed ergonomica nell'uso di tutti i giorni, lascia la libertà di disporla dove si desidera e dove può dare un tocco in più all'arredamento grazie al rivestimento colorato.

The essential in cooking

Heating and cooking with a few, simple steps. With Smart, the Cadel free-standing wood cooker, there is precisely a smart way of doing it, as it is made with an essential, functional design: the perfect help to provide comfort at home. Practical and ergonomic in everyday use, you can place it wherever you want and its colourful coating adds an extra touch to interiors.

L'essentiel en cuisine

Chauffer et cuisiner avec quelques gestes simples. Avec Smart, la cuisinière à bois freestanding de la société Cadel, il est possible de le faire intelligemment, car elle est créée avec une essentialité fonctionnelle, la complice parfaite du bien-être de la maison. Pratique et ergonomique pour l'utilisation quotidienne, elle peut être placée où on le souhaite et donner une touche en plus à la décoration, grâce au revêtement en couleur.

Das wesentliche in der Küche

Heizen und Kochen mit wenigen einfachen Gesten. Smart der freestanding Holzofen von Cadel ermöglicht es auf intelligente Weise, da er essentiell und funktionstüchtig ausgelegt ist, der perfekte Partner heimischen Wohlbefindens. Praktisch und ergonomisch im täglichen Gebrauch, kann er überall und wo er mit seiner farbigen Verkleidung der Einrichtung eine besondere Note verleiht platziert werden.

Smart collection

SMART - 6 KW

-  6 kW
-  71,5 %
-  144 m³
-  Legna - Wood - Bois - Holz
-  1,8 kg/h
-  Ø 120 mm
-  132 kg
-  L 82 - P 55 - H 85 cm
-  4 cm
-  L 29,5 - P 38,5 - H 22 cm
-  L 18 - H 13,5 cm
-  0,59 m³

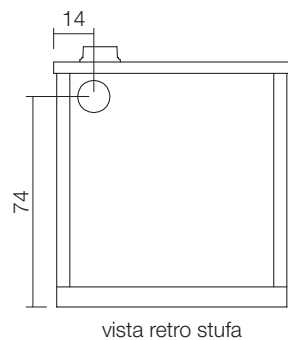
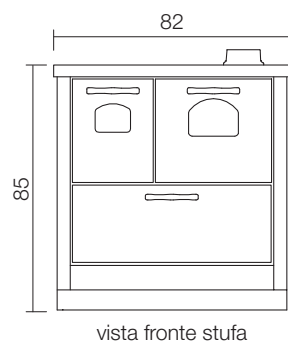
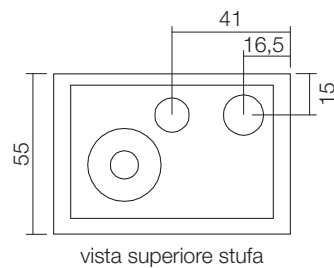

Maiolica - Majolica - Céramique - Keramik



Avorio	Rosso
Ivory	Red
Ivoire	Rouge
Elfenbein	Rot



Metallo - Steel - Acier - Metall



Avorio	Rosso
Ivory	Red
Ivoire	Rouge
Elfenbein	Rot



EN 12815:2001/A1:2004/AC:2007

Cucine a Legna
libera installazione
KOOK 87 - 7,5 kW



Kook 87

Scalda e cucina dove vuoi tu!

Heat and cook wherever you want!

Chauffage et cuisson ou nous voulons !

Wärmen Sie auf und kochen Sie wo Sie wollen!



 KOOK

Cucine a Legna
libera installazione
KOOK 87 - 7,5 kW



Kook 87



Interno in refrattario con aria 2^a combustione
Refractory stone inner with 2nd combustion air
Intérieur réfractaire à apport d'air secondaire
Feuerraum aus Schamotte mit Sekundärluftverbrennung



Cucinare
Cooking
Cuisiner
Kochen



Vista sul forno
View on the oven
Vue sur le four
Sicht des Backofens



Maniglia anti ustione
Burnproof handle
Poignée anti brûlure
Isolierter Griff



OPTIONAL
Kit ventilazione + luce / Ventilation + light kit
Ventilation + éclairage / Lüftung kit + Beleucht



Scarico fumi superiore destro e posteriore destro
Upper right and back right exhaust
Évacuation supérieureet postérieure droite
Abgasstutzen Oben und Hinten Rechts

Cucine a Legna
libera installazione
KOOK 87 - 7,5 kW



Scalda e cucina dove vuoi tu!

Per chi cerca un sistema tradizionale e moderno di riscaldare e cuocere in modo naturale, Kook 87 è la soluzione ideale. Una cucina a legna a libera installazione dalle pregiate finiture che danno un tocco di carattere all'ambiente combinando alla sua estrema funzionalità uno stile unico. Oltre al rivestimento in metallo, Cadel propone anche la versione rivestita con raffinate maioliche artigianali disponibili in due colori per dare un'impronta romantica ed elegante alla vostra cucina.

Heat and cook wherever you want!

For those seeking a traditional and modern system to heat and cook in a natural way, Kook 87 is the ideal solution. A wood cooker that you can install wherever you want and featuring fine finishes that add a distinctive touch to the environment by combining extreme functionality with unique style. Along with the metal coating, Cadel also offers fine, handcrafted majolica coating available in two colours to add an elegant, romantic feel to your kitchen.

Chauffage et cuisson ou nous voulons !

Pour ceux qui veulent rendre le feu protagoniste dans leur maison, ou pour ceux qui cherchent un moyen de chauffage et de cuisson en même temps moderne et traditionnel, Kook 87 est la solution. Une cuisinière en pose libre avec des finitions très recherchées qui donne une touche de caractère à l'ambiance, en réunissant sa grande fonctionnalité à son style unique. Cadel propose un revêtement en métal et une version avec finition en céramique artisanale, disponible en deux couleurs pour donner une empreinte romantique et élégante à vos cuisines. Kook 87 avec ses couleurs et son dessin deviendra le centre d'attention de la cuisine.

Wärmen Sie auf und kochen Sie wo Sie wollen!

Wer auf der Suche nach einem traditionellen und modernen System zum Aufwärmen und Kochen auf natürliche Weise ist, findet in Kook 87 die ideale Lösung. Ein Holzherd mit ungebundener Installation mit einem wertvollen Finish, das auch in das Ambiente Charakter bringt. Extreme Zweckmäßigkeit und einzigartiger Stil. Neben der Verkleidung aus Metall schlägt Cadel auch die Version mit einer wertvollen Verkleidung aus handwerklicher Majolika vor, die in zwei verschiedenen Farben erhältlich ist und Ihre Küche romantisch und elegant erscheinen lässt.

KOOK 87 - 7,5 kW

-  7,5 kW
-  82,5 %
-  180 m³
-  Legna - Wood - Bois - Holz
-  2,2 kg/h
-  Ø 140 mm
-  140 kg - 172 kg
-  L 90 - P 60 - H 85,7 cm
-  4 cm
-  L 33 - P 42 - H 29 cm
-  L 17,2 - H 16,7 cm
-  0,68 m³

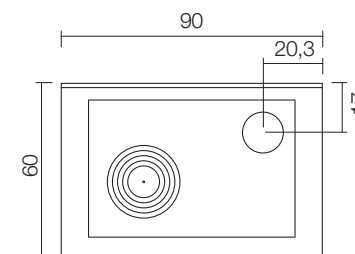

vista superiore stufa

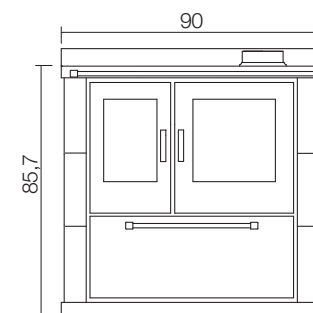

vista fronte stufa

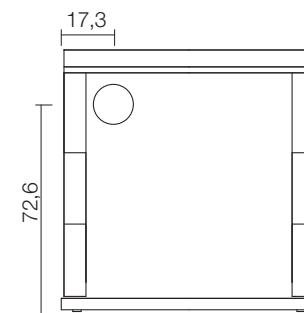

vista retro stufa



EN 12815:2001/A1:2004/AC:2007



NORMATIVE EUROPEE: Art. 15A-B-VG 2015 BImSchV 2015 Regensburg München Stuttgart Aachen

Kook 87 collection



Maiolica - Majolica - Céramique - Keramik



Avorio	Rosso
Ivory	Red
Ivoire	Rouge
Elfenbein	Rot



Metallo - Steel - Acier - Metall

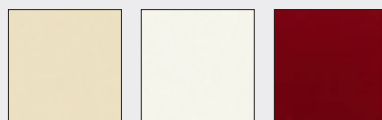

Avorio	Bianco	Rosso
Ivory	White	Red
Ivoire	Blanc	Rouge
Elfenbein	Weiss	Rot

Demetra



Posizione griglia fuoco per cottura
Position of the fire rack
in cooking mode
Position grille feu pour cuisson
Position des Feuergitters zum Kochen



Posizione griglia fuoco
per riscaldamento
position of the fire rack
in heating mode
Position grille feu pour chauffage
Position des Feuergitters zum Heizen



Porta in acciaio
Steel door
Porte en acier
Tür aus Stahl



Raccordi idraulici
Hydraulic fittings
Raccords hydrauliques
Hydraulikanschlüsse



Termocucina: multifunzionalità al tuo servizio

La termocucina è uno strumento estremamente funzionale, un vero aiuto per la cucina e per tutta la casa. Si rifà alle antiche tradizioni, sfruttando la legna come combustibile e si avvale delle più moderne tecnologie per sfruttare al massimo il calore e destinarlo in più usi. Con le termocucine a legna è possibile cucinare, riscaldare i cibi e l'ambiente e alimentare l'impianto di riscaldamento di tutta la casa grazie al circuito idraulico composto da serpentine in acciaio.



Thermo cooker: multifunctionality at your service

A thermo cooker is an extremely functional tool providing real support in the kitchen and for the whole house. It draws inspiration from tradition, making the most of wood in terms of fuel and employing the latest technology to make full use of heat and use it for several purposes. With wood-burning thermo cookers you can heat food and the room and feed the heating system for the whole house thanks to the hydraulic circuit consisting of steel coils.



Thermo-cuisinière: multifonctionnalité à votre service

La thermo-cuisinière est un instrument extrêmement fonctionnel, une vraie aide pour la cuisine et pour toute la maison. Elle revient aux vieilles traditions, en exploitant le bois comme combustible et utilise les technologies les plus modernes pour exploiter au maximum la chaleur et la destiner à plusieurs utilisations. Avec les thermo-cuisinières à bois il est possible de cuisiner, chauffer les aliments et la pièce et alimenter l'installation de chauffage de toute la maison grâce au circuit hydraulique composé de serpentin en acier.



Thermoherd: Multifunktion zu Ihren Diensten

Der Thermoherd ist ein extrem funktionsdienliches Instrument, eine richtige Hilfe in der Küche und in der ganzen Wohnung. Holz als Brennstoff nach antiker Tradition und fortschrittliche Technologie, um die Hitze in höchstem Ausmaß und für mehrere Zwecke zu nutzen. Mit den Holz-Thermoöfen kann man kochen, die Speisen wärmen und den Raum aufheizen und die Heizanlage der ganzen Wohnung dank des aus Wärmeschlangen bestehenden Hydraulikkreislaufes versorgen.

Termocucine
DEMETRA - 21,6 kW



Demetra



Collegamento all'impianto di riscaldamento
Connection to the heating system
Liaison avec installation de chauffage
Anschluss zu Heizungssystem



Cucinare
Cooking
Cuisiner
Kochen



Vista sul forno
View on the oven
Vue sur le four
Sicht des Backofens



Maniglia anti ustione
Burnproof handle
Poignée anti brûlure
Isolierter Griff



Collegamento termostato esterno
Connection to the external thermostat
Liaison thermostat externe
Anschluss zu Außenthermostat



Scarico fumi superiore destro e posteriore destro
Upper right and back right exhaust
Évacuation supérieure et postérieure droite
Abgasstutzen Oben und Hinten Rechts